

# MT Series – Tubes with variable chain widths

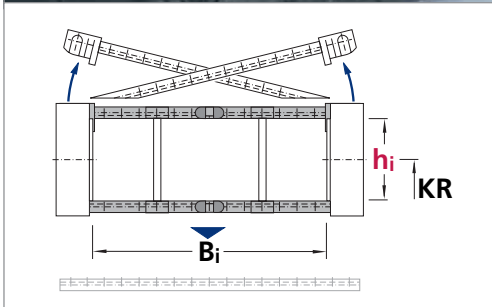

- Available in 1, 8 or 16 mm width sections
- Can be opened quickly on the inside and the outside for cable laying
- Solid plastic or in combination with aluminium cover system
- Enclosed stroke system not sensitive to dirt/contamination
- Transmission of forces (tensile and shearing forces) over a large surface area via the optimum link design – according to the “life extending 2 disc principle”
- Standard universal mounting brackets (UMBs), suitable for any assembly situation
- Numerous ways of separating the cables
- Highly wear-resistant, replaceable glide shoes available – resulting in minimal wear at high speeds, sliding in the guide channel
- Optionally available with different strain relief systems
- TÜV design approved in accordance with 2PfG 1036/10.97

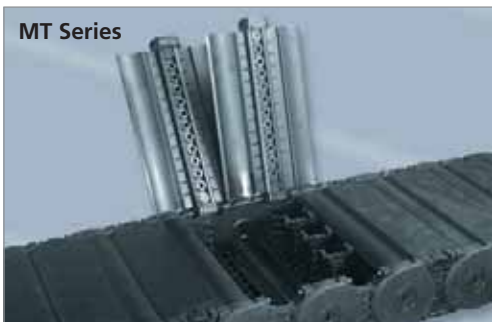

## Types MT 0475, 0650, 0950 and 1250 with plastic cover system (stay variant RDD)

**Solid plastic**

Available in 8 or 16 mm width sections

Dimensions in mm

Type	hi	Bi	Maximum travel length in m	Dynamics of unsupported arrangement		Page
				Travel speed v <sub>max</sub> in m/s	Travel acceleration a <sub>max</sub> in m/s <sup>2</sup>	
MT 0475	26	24-280	100	10	40	151
MT 0650	38,5	50-258	170	8	35	151
MT 0950	54,5	77-349	230	6	25	151
MT 1250	68,5	103-359	270	5	20	151

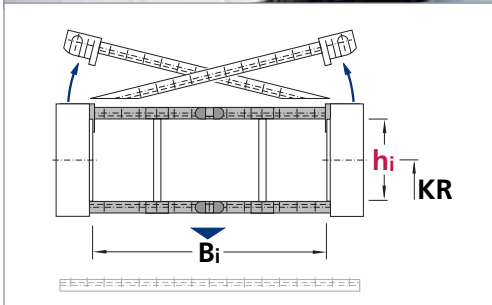
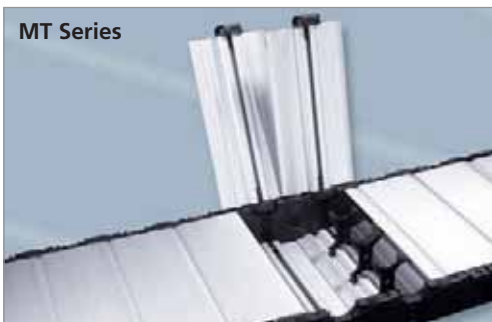

## Types MT 0475, 0650, 0950 and 1250 with aluminium cover system (stay variant RMD)

**Plastic and aluminium combination**

Available in 1 mm width sections



Dimensions in mm

Type	hi	Bi	Maximum travel length in m	Dynamics of unsupported arrangement		Page
				Travel speed v <sub>max</sub> in m/s	Travel acceleration a <sub>max</sub> in m/s <sup>2</sup>	
MT 0475	26	24-180	100	10	40	151
MT 0650	38.5	100-500	170	8	35	151
MT 0950	54.5	100-600	230	6	25	151
MT 1250	68.5	150-800	270	5	20	151

# Types MT 0475, 0650, 0950 and 1250

## Carrier construction and cover systems

### Plastic cover system (stay variant RDD)



#### Covered solid plastic cable carriers

##### MT 0475, 0650:

Available in **8 mm width sections**.

##### MT 0950, 1250:

Available in **16 mm width sections**.



#### Opening options:

**Outside:** Simply by levering the cover open (on the right or left).  
Cover can also be removed

**Inside:** Simply by turning the cover

MT 0475 is available with a cover that can be levered open to the inside.  
Please specify when ordering.

### Aluminium cover system (stay variant RMD)



#### Covered hybrid cable carriers

##### MT 0475, 0650, 0950 and 1250

Available in **1 mm width sections**.



#### Opening options:

**Outside:** Simply by levering the cover open (on the right or left).  
Cover can also be removed

**Inside:** Simply by turning the cover

MT 0475 is available with a cover that can be levered open to the inside.  
Please specify when ordering.

# Types MT 0475, 0650, 0950 and 1250

## Dimensions and intrinsic chain weight

### Plastic cover systems (stay variant RDD)

Dimensions in mm/Weights in kg/m

Type	Stay variant	$h_i$	$h_G$	$B_i$ min	$q_k$ min	$B_i$ max	$q_k$ max	$B_k$
MT 0475	RDD	26	39	24	0.9	280	4.4	$B_i + 17$
MT 0650	RDD	38.5	57	50	2.4	258	3.7	$B_i + 34$
MT 0950	RDD	54.5	80	77	4.3	349	7.7	$B_i + 39$
MC 1250	RDD	68.5	96	103	5.7	359	8.9	$B_i + 45$

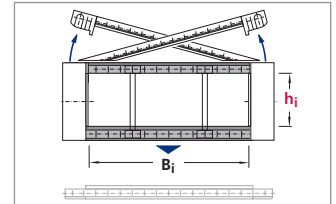
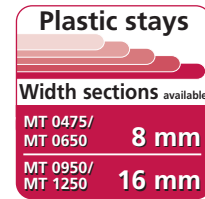

### Aluminium cover systems (stay variant RMD)

Dimensions in mm/Weights in kg/m

Type	Stay variant	$h_i$	$h_G$	$B_i$ min	$q_k$ min	$B_i$ max	$q_k$ max	$B_k$
MT 0475	RMD	26	39	24	0.9	180	4.5	$B_i + 17$
MT 0650	RMD	38.5	57	100	3.3	500	9.7	$B_i + 34$
MT 0950	RMD	54.5	80	100	5.5	600	16.2	$B_i + 39$
MC 1250	RMD	68.5	96	150	9.0	800	26.0	$B_i + 45$

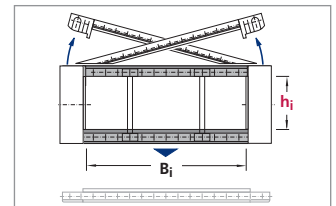

## Bend radius and pitch

Dimensions in mm

Type	Bend radii KR							
MT 0475	75	100	130	160	200	250	300	350
MT 0650	95*	115	145	175	220	275	300	
MT 0950	140*	170*	200	260	290	320	380	
MT 1250	220*	260	300	340	380	500		

Pitch:

MT 0475:  $t = 47.5$  mm

MT 0650:  $t = 65$  mm

MT 0950:  $t = 95$  mm

MT 1250:  $t = 125$  mm

\* not with aluminium cover system RMD.

## Load diagram

for unsupported length  $L_f$  depending on the additional load

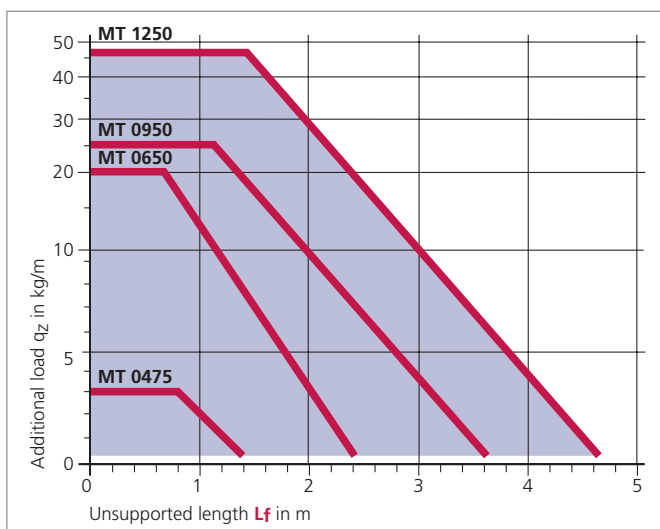

Unsupported length  $L_f$

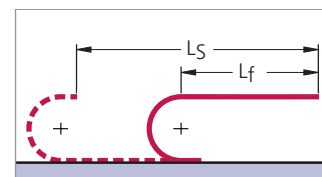

In the case of longer travel lengths, sag of the cable carriers is technically permissible depending on the application.

In a gliding arrangement, even longer travel lengths are possible (see page 219).

We are at your service to advise on these applications.

# Types MT 0475, 0650, 0950 and 1250

## Divider systems

### Divider system TS 0

Type	Stay variant	$h_i$ mm	$S_T$ mm	$a_T$ min mm	$a_x$ min mm	$a_x$ section mm
MT 0475	RDD	26	2.8	12	8	8
MT 0475	RMD	26	2.8	6	8	–
MT 0650	RDD	38.5	4.2	13	16	8
MT 0650	RMD	38.5	3	16	13	–
MT 0950	RDD	54.5	6	22.5	16	16
MT 0950	RMD	54.5	4	7	14	–
MT 1250	RDD	68.5	8	19.5	16	16
MT 1250	RMD	68.5	5	10	20	–

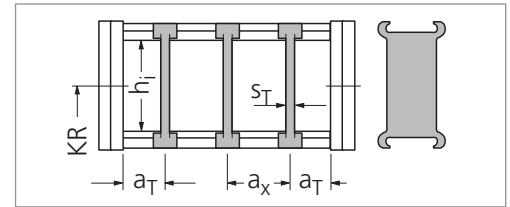

In the standard version, the divider systems are mounted on every second chain link.

With plastic cover systems (RDD), the dividers are fixed in the cross-section at intervals of  $a_x$ -section. With aluminium cover systems (RMD), the dividers can be moved.

### Divider system TS 1

with continuous height subdivision made of aluminium

Type	Stay variant	$h_i$ mm	$S_T$ mm	$a_T$ min mm	$a_x$ min mm	$a_x$ section mm	$S_H$ mm	$h_1$ mm	$h_2$ mm
MT 0475	RDD	26	2.8	12	8	8	2.4	15	–
MT 0475	RMD	26	2.8	6	8	–	2.4	15	–
MT 0650	RDD	38.5	4.2	13	16	8	4	10	22
MT 0650	RMD	38.5	3	16	13	–	4	–	–
MT 0950	RDD	54.5	6	22.5	16	16	4	22	–
MT 1250	RDD	68.5	8	19.5	32	16	4	32	–

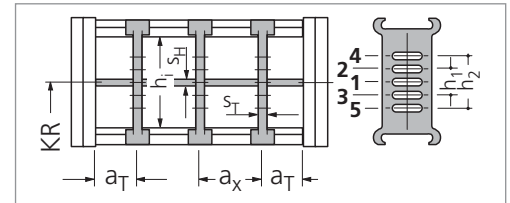

In the standard version, the divider systems are mounted on every second chain link.

With plastic cover systems (RDD), the dividers are fixed in the cross-section at intervals of  $a_x$ -section. With aluminium cover systems (RMD), the dividers can be moved.

### Divider system TS 2

with aluminium height subdivision. Available in 1 mm width sections.

Type	Stay variant	$h_i$ mm	$S_T$ mm	$a_T$ min mm	$a_x$ min mm	$a_x$ section mm	$S_H$ mm	$h_1$ mm
MT 0475	RDD	26	2.8	12	8	8	2.4	15
MT 0650	RDD	38.5	4.2	13	16	8	4	10

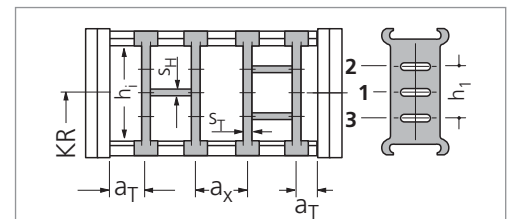

In the standard version, the divider systems are mounted on every second chain link.

# Types MT 0475, 0650, 0950 and 1250

## Divider systems

### Divider system TS 3

with partitioned height subdivision made of plastic

Type	Stay variant	$h_i$ mm	$S_T$ mm	$a_T$ min mm	$a_x$ min mm	$S_H$ mm	$h_1$ mm	$h_2$ mm	$h_3$ mm	$h_4$ mm
MT 0950	RDD	54.5	8	6.5	16*	4	14	28	42	–
MT 1250	RDD	68.5	8	4	16*	4	14	28	42	56

\* When using plastic partitions

With plastic cover systems (RDD), the dividers are fixed in the cross-section.

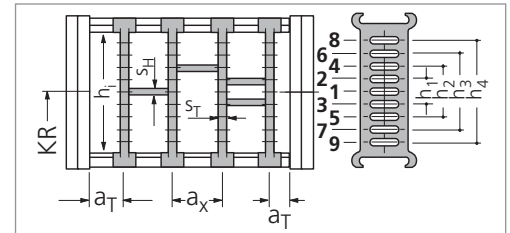

In the standard version, the divider systems are mounted on every second chain link.

### Dimensions of plastic partitions for TS 3

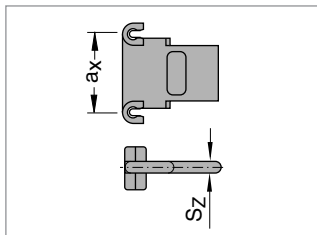

Aluminium partitions in 1 mm width sections are also available.

$S_Z$	$a_x$ (center-to-center distance, dividers)									
	4	16	32	48	64	80	96	112	128	144
	176	192	208							

Dimensions in mm

When using **partitions with  $a_x > 112$  mm**, there should be an additional central support with a **twin divider** ( $S_T = 4$  mm). Twin dividers are designed for subsequent fitting in the partition system. You can find further information on this in our main catalog.

## Gliding elements – the economical solution for gliding applications

### Replaceable glide shoes



#### Replaceable glide shoes made of plastic

To extend the life of cable carriers in gliding operations KABELSCHLEPP supplies detachable, exchangeable glide shoes.

Replaceable glide shoes are a very economical solution. When wear occurs only the glide shoes are replaced, and not the complete cable carrier.

For travel speeds  $> 2.5$  m/s and large additional loads, a highly wear-resistant special material is used.

For type MT 0950 **OFFROAD glide shoes** with 70 % greater wear volumes are also available. We recommend their use in extreme environmental conditions (with particularly abrasive materials such as e. g. sand, dust, corundum).

**!** By means of a positive snap connection, the glide shoes sit firmly on the chain link.

#### Chain height with glide shoes: (Dimensions in mm)

<b>MT 0475:</b>	$h_G' = h_G + 2.5 = 41.5$
<b>MT 0650:</b>	$h_G' = h_G + 3.2 = 60.2$
<b>MT 0950:</b>	$h_G' = h_G + 3.5 = 83.5$
<b>MT 1250:</b>	$h_G' = h_G + 3.5 = 99.5$

In the case of the type MT 0475, with the bend radius  $KR = 75$  mm no glide shoes can be used.

# Types MT 0475, 0650, 0950 and 1250

## Minimized hinge wear owing to the "life extending 2 disc principle"

In the M Series\*, the push and pull forces are transmitted via the optimum link design for this purpose.

As a result link wear is reduced to a minimum and the life of the cable carrier is considerably lengthened.

\* not for type 0320

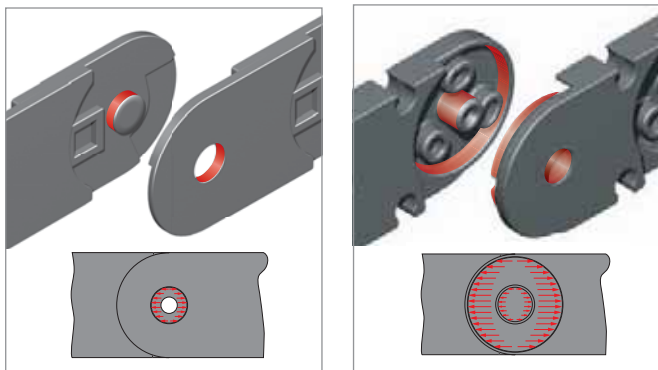

■ Force transmission with a pin-hole joint

■ Force transmission with the "life extending 2 disc principle"

## Connection dimensions type MT 0475

### Connectors of plastic/steel

#### End connector of steel plate.

Screwable strain relief of aluminium on inquiry.

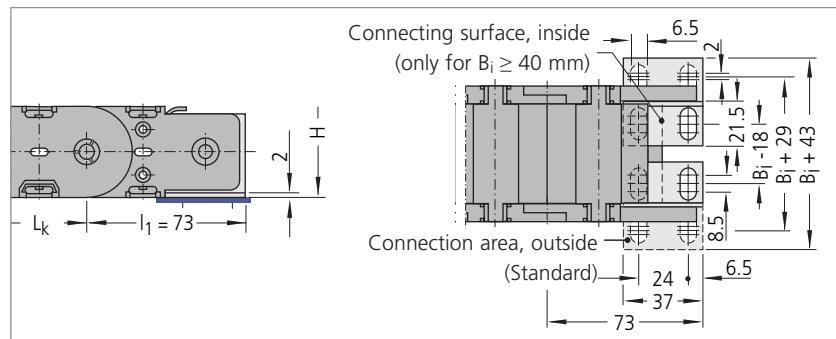

The dimensions of the fixed point and drive connections are identical.

## Connection variants type MT 0475

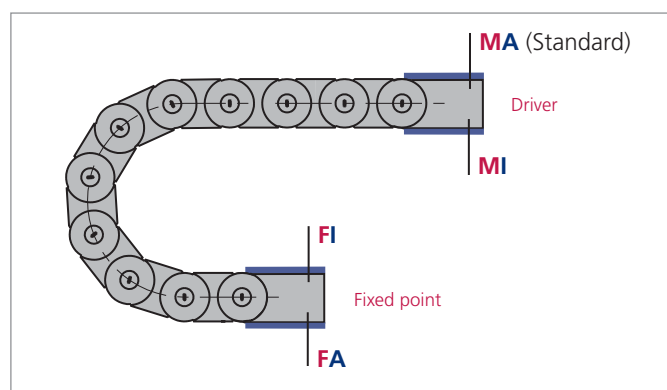

#### Connection point

- M** – Driver
- F** – Fixed point

#### Connection type

- A** – Threaded joint (standard)
- I** – Threaded joint, inside

In the standard version, the end connectors are mounted with the threaded joint outwards (**FA/MA**).

When ordering please specify the desired connection type (see ordering key on page 246).

The connection type can subsequently be altered simply by changing the connectors.

# Types MT 0475, 0650, 0950 and 1250

## Connection dimensions type MT 0650

### UMB-connectors of aluminium

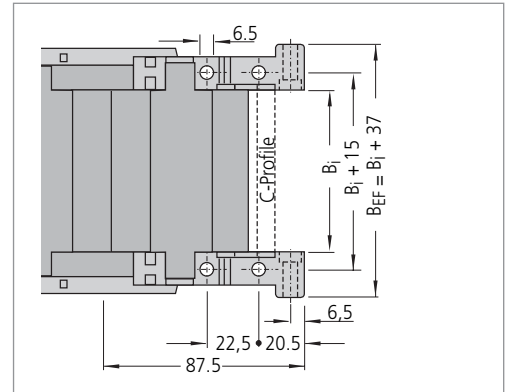
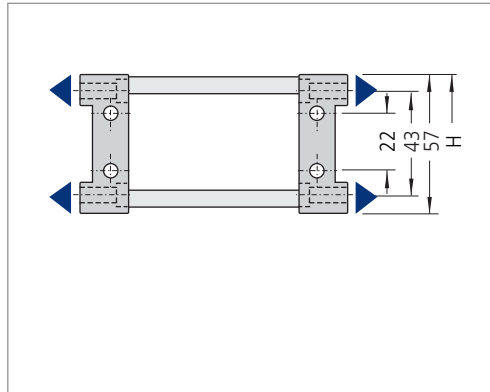
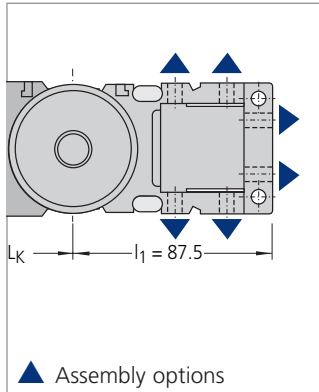

The dimensions of the fixed point and drive connections are identical.

Optionally with C-Profile, slot width 11 – 12 mm, suitable for KABELSCHLEPP SZL strain reliefs and all common commercial shackle straps with small foot (see chapter guide channels and other accessories, from page 219 onwards).

End connectors of steel plate available on inquiry.

## Connection dimensions types MT 0950 and 1250

### UMB-connectors of aluminium

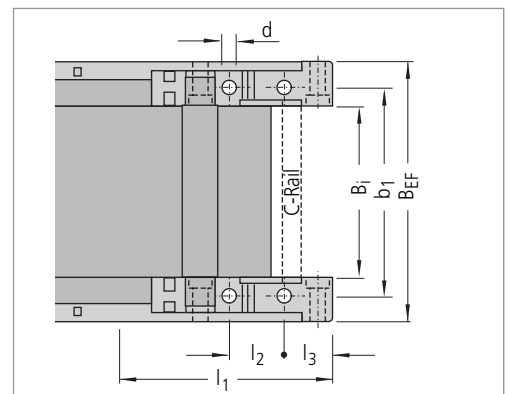
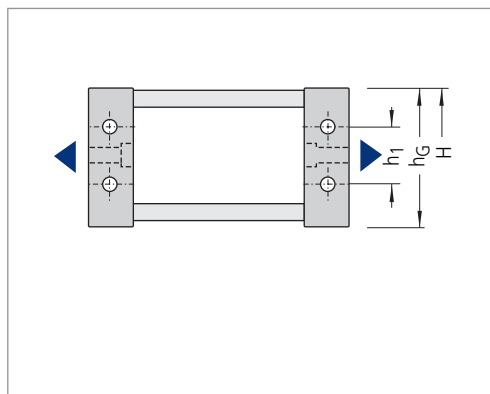
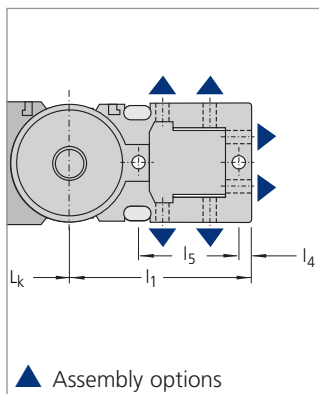

The dimensions of the fixed point and drive connections are identical.

Optionally with C-Rail, slot width 16 – 17 mm, suitable for KABELSCHLEPP SZL-strain reliefs and all common commercial shackle straps with large foot (see chapter guide channels and other accessories, from page 219 onwards).

End connectors of steel plate available on inquiry.

Dimensions in mm

Type	$B_{EF}$	$b_1$	$d$	$l_1$	$l_2$	$l_3$	$l_4$	$l_5$	$h_1$	$h_G$
MT 0950	$B_i + 44$	$B_i + 24.5$	8.5	136	35	24.5	8.5	80	45	80
MT 1250	$B_i + 51$	$B_i + 28$	11	168	35	31	10.5	94.5	45	96

$B_{EF}$  = Chain width over connector